

# SERPAC 171

Electronics Enclosures

NOTES:  
1. WHEN MACHINE OR I PLATES MODIFICATIONS ARE REQUIRED, USE THE CENTER OF THE BOX TO DIMENSION.

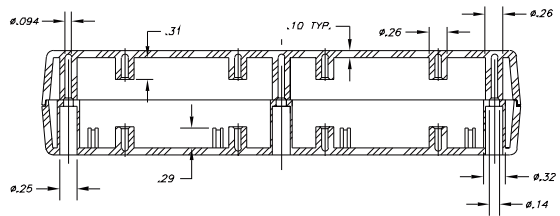
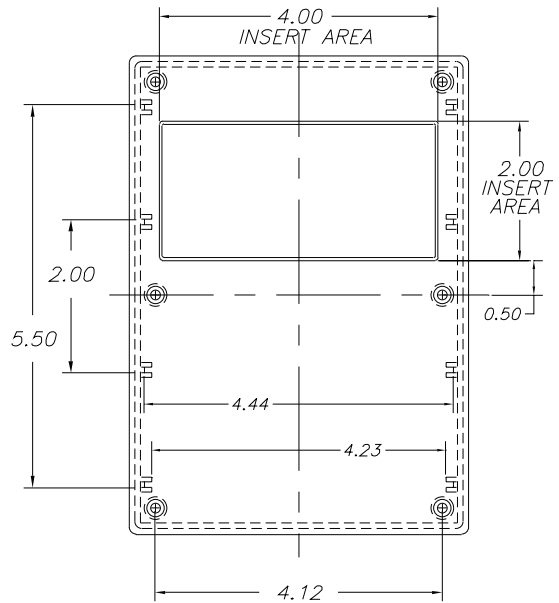
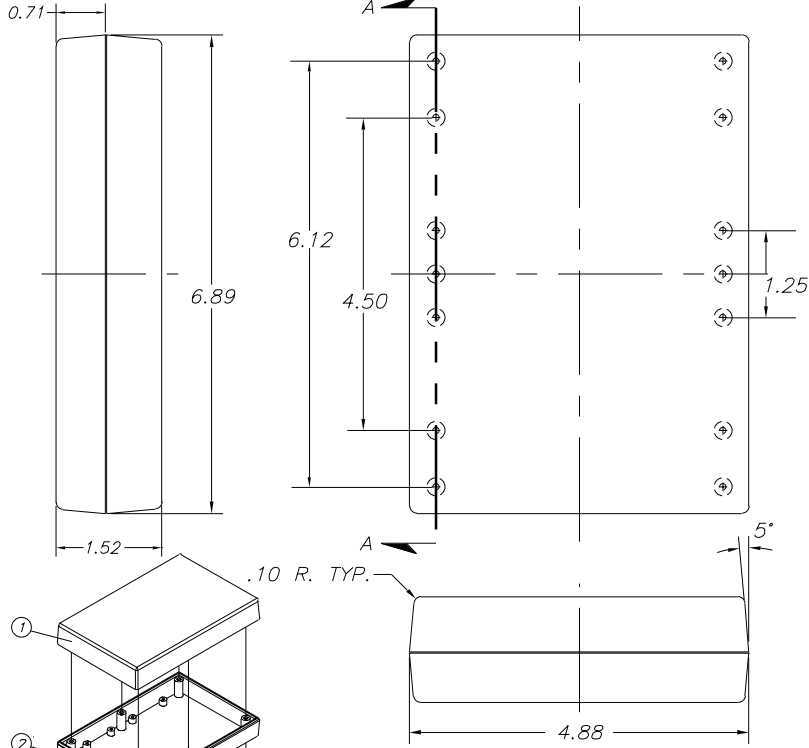

8-17-98. ALL DIMENSIONS ± .010

ITEM	PART NO.	DESCRIPTION	PART NO.	ACCESSORIES DESCRIPTION
1	71	PLASTIC TOP	50	FEET
2	17	PLASTIC BOTTOM	370	PROTOTYPE GRID BOARD (HORIZ.)
3	6005	SCREWS (6)	470	PROTOTYPE CLAD BOARD (HORIZ.)
			371	PROTOTYPE GRID BOARD (VERT.)
			471	PROTOTYPE CLAD BOARD (VERT.)

SECTION A-A

# SERPAC 171-I

Electronics Enclosures

NOTES:  
1. WHEN MACHINE OR I PLATES MODIFICATIONS ARE REQUIRED, USE THE CENTER OF THE BOX TO DIMENSION.

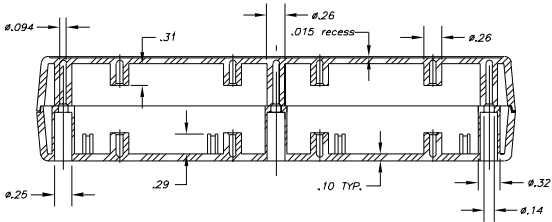
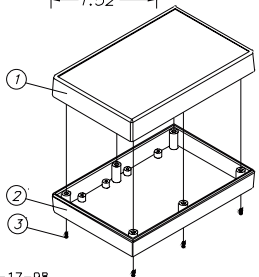
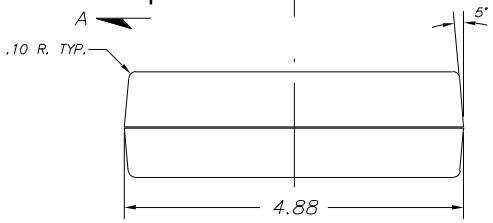
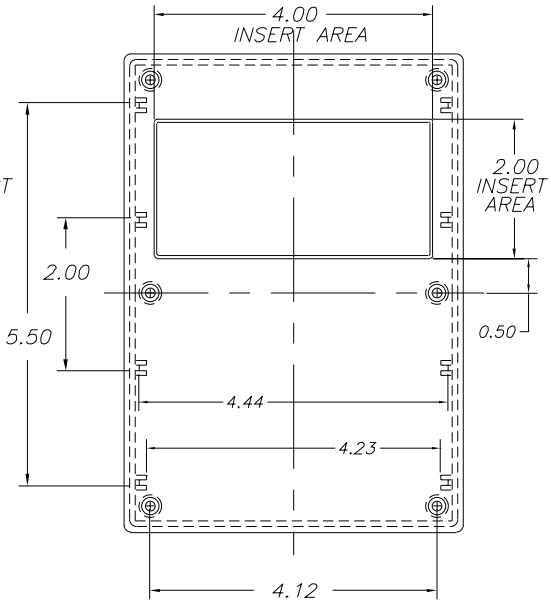
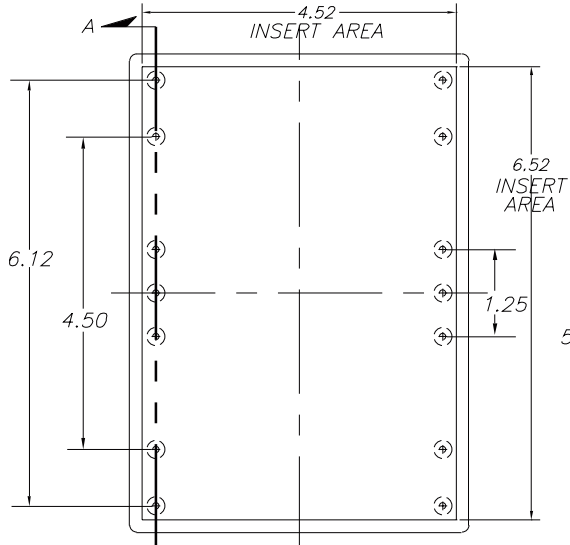
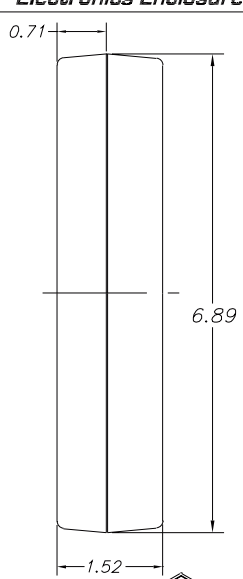

8-17-98. ALL DIMENSIONS ± .010

ITEM	PART NO.	DESCRIPTION	PART NO.	ACCESSORIES DESCRIPTION
1	711	PLASTIC TOP	50	FEET
2	17	PLASTIC BOTTOM	370	PROTOTYPE GRID BOARD (HORIZ.)
3	6005	SCREWS (6)	470	PROTOTYPE CLAD BOARD (HORIZ.)
			371	PROTOTYPE GRID BOARD (VERT.)
			471	PROTOTYPE CLAD BOARD (VERT.)

SECTION A-A